

ON-LINE SDI-12 FORM

The SDI-12 web site has been on-line for over a year and has served the public and its membership well. By being present on the Internet and providing this information on-line, we are fulfilling several purposes of the Group, namely to provide information about SDI-12 and to maintain the SDI-12 Specification. To fulfill these goals, we plan to make the site more interactive. We plan to create a forum on the site to provide an open venue to express comments and ask questions.

Simply entitled "The Billboard", this forum will be open to all issues that pertain to the SDI-12 protocol and its application. It is not intended to operate as a newsgroup. Your comments do not have to be interactive, nor are they required to be within a certain context except SDI-12. For instance, someone might post a technical message which could later appear in the newsletter or be reviewed by the Technical Committee. It would also enable first-time visitors to ask a basic question which was not answered elsewhere. This could be answered by me by reference to certain pages within the site, or by allowing the Chairman or Technical Committee Chairman to answer at their discretion. Yet another possibility is that a visitor posts a message requesting a product of some description. In this instance, I would urge vendors to reply directly to the e-mail address that will be posted with the message in order to promote their product.

It is hoped that "The Billboard" will satisfy the SDI-12 Support Group membership and that it will fulfill the purpose for which it is intended. Coming soon to your neighborhood! Contact me for any comments or suggestions:

Marcel Leclerc
AMASS Data Technologies, Inc.
amassinf@amassdata.com
(819) 457-4926
(613) 345-1883 FAX

WIRELESS SDI-12

The SDI-12 membership has expressed an interest in wireless SDI-12. The technical committee reviewed this topic at the 1997 technical committed meeting. The conclusion was that SDI-12's timing constraints make a general purpose, low power, SDI-12 wireless link unfeasible. The timing for wireless communication would be faster and incompatible with the current SDI-12 specification. The development of a wireless SDI-12 specification would, therefore, require writing a new specification. That specification would be incompatible with existing SDI-12 equipment. If the SDI-12 membership expresses a strong desire for a wireless specification, however, the technical committee will commence work on this.

TECHNICAL ISSUES

There are several technical issues pending with the SDI-12 specification. These subjects were discussed at our meetings last fall. Final action on these issues will

most likely be decided upon during our meetings in November of 1998.

Cyclic Redundancy Check (CRC). The technical committee discussed several means of implementing new commands and using a CRC for detection of serial communication errors. There are many means of computing a CRC in common use. The committee is working on a proposal for the best computation of a CRC and how to use a CRC with SDI-12 commands.

Long Data Lines and Differential SDI-12.

To allow longer data lines, the technical committee is investigating the use of differential SDI-12. (SDI-12 currently specifies cable lengths of up to 200 feet between a sensor and a data recorder.) The objective is to determine whether differential SDI-12 can be implemented in a way that will be compatible with the existing single ended SDI-12 sensors and data recorders.

Other Technical Proposals.

There are three other technical issues pending:

1. Changing the data line "off" impedance from a fixed value to a range of values in the SDI-12 specification.

2. Eliminating the vague wording in the specification about not inductively loading the power line and modify the recommended connection to 12V by adding a series diode. This should eliminate problems caused by induction loads and problems caused when users make

(Continued on page 2)

(Technical Issues Continued . . .)
connection errors.

3. Better define the term "low-power standby mode", explaining that this is a protocol state and a power consumption mode.

Comments are welcome about these or any other technical issues about SDI-12.

OUR NEXT MEETING

Each year the SDI-12 Support Group holds its annual meetings in conjunction with the American Water Resources Association's (AWRA) annual conference. This year that conference will be held on November 15-19 in Point Clear, Alabama. All members of the SDI-12 Support Group will receive a announcement for the SDI-12 meetings at least 30 days prior to the conference. That announcement will contain an agenda for the technical committee meeting and an agenda for the general meeting of the Support Group. Please plan on attending the meetings. Each year many members of the SDI-12 Support Group have enjoyed technical discussions about SDI-12, had an opportunity to meet with professionals that use SDI-12 equipment, and have a voice in Support Group.

All are welcome at our annual meetings.

SDI-12 VERIFIER

The SDI-12 Verifier software is currently at Version 2.2, which tests Version 1.2 of the SDI-12 Specification. This version tests the commands which are new to Version 1.2. of SDI-12. This includes the concurrent measurement command, the change address command, and the continuous measurement commands. For more information about the SDI-12 Verifier, please call NR Systems, Inc, 435-752-4200.

COMMON PROBLEM USING SDI-12

I have been working with SDI-12 since 1992. Since that time I have had the opportunity to work with many SDI-12 data recorders and sensors. In my experience, the most common mistake that I have seen is that data recorders have failed to implement retries. The best way to implement retries is to use the logic shown on the data recorder flow chart found in appendix B-1 of the SDI-12

specification. That algorithm is robust and gives an SDI-12 sensor every opportunity to respond to an SDI-12 command. If a sensor wakes up immediately upon detection of a break, the logic in that algorithm quickly reads the response from the sensor and the command/response sequence is done. If the sensor needs time to wake up, the algorithm issues sufficient retries to allow the sensor time, within the specification, to wake up and respond to a command. If a sensor fails to wake up and respond to a command within the allowed time (100 milliseconds), the algorithm provides a extra margin to give the sensor additional chances to respond to the command.

Figure 1 shows the timing of these retries. In figure 1 a sensor is sending commands but there is no sensor on the bus responding to the commands. Figure 1 shows a three byte command, such as aM!. Two retries are issued even after 100 milliseconds has elapsed since the end of the break. This gives a sensor ample opportunity to respond to a command.

Figure 2 shows the same time timing including two additional breaks followed by the retries. This gives the sensor even more

opportunity to respond to the command. If a sensor requires more than one break to wake up, it is out of compliance with the specification, yet a data recorder using this algorithm will still communicate with the sensor.

(Continued on pg 3)

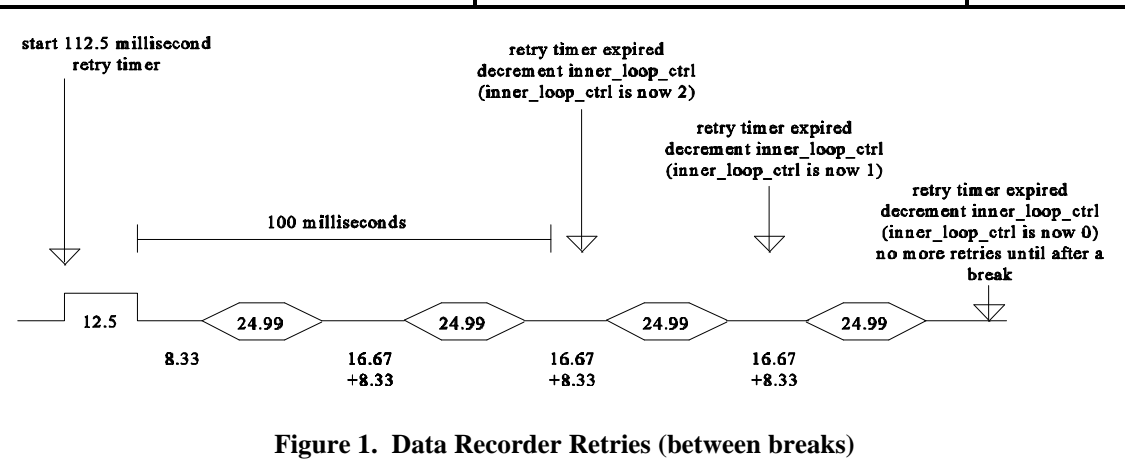

SDI-12 SUPPORT GROUP CORPORATE NEWS

SUMMER 1998

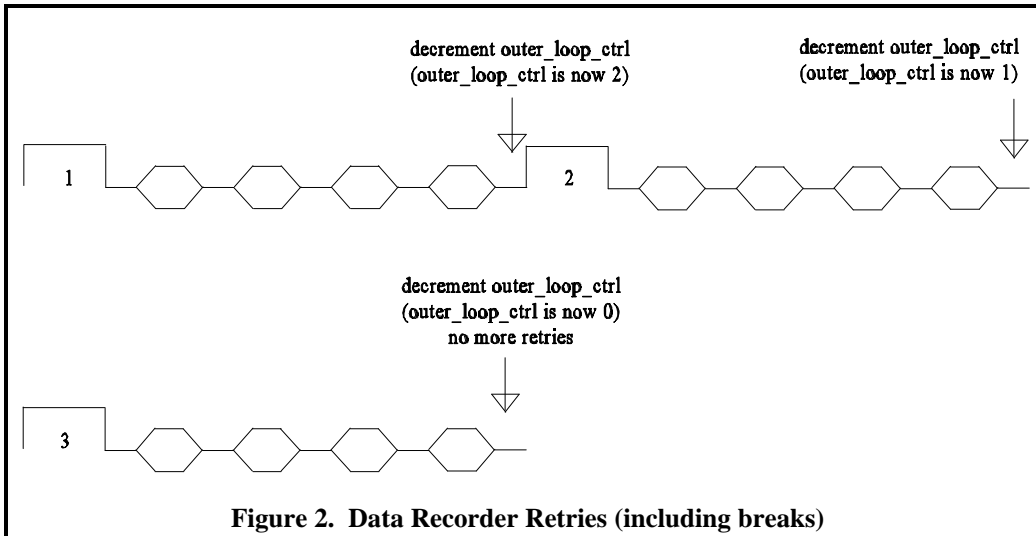

BOARD OF DIRECTORS

Mike Jablonski, Chairman
(NR Systems, Inc.)
Gerald Calhoun, Board Member
(Sutron Corporation)
William P. Thomas, Secretary
(AMASS Data Technologies, Inc.)

TECHNICAL COMMITTEE

Gerald Calhoun, Chairman
Sutron Corporation
21300 Ridgetop Circle
Sterling, VA 20166
703-406-2800 /703-406-2801(FAX)

Paul-Emile Bergeron
Environment Canada
131 Gerber Blvd.
Gatineau, Quebec
Canada J8T 3R1
819-997-1398/819-953-2387 (FAX)

Jim Betzhold
South Florida Water Management District
Building A-100
7257 West Port Place
West Palm Beach, Florida 33413
407-687-6972/407-697-7291 (FAX)

Terry Dickey
Hydrolab
PO Box 50116
Austin, TX 78763
512-255-8841/512-255-3106 (FAX)

William P. Thomas
AMASS Data Technologies, Inc.
34 Chemin Hélène
Val des Monts, Quebec
J8N 2L7
613-345-1135/613-345-1883(FAX)

(Common Problems continued . . .)

Whenever I talk with a company that is first getting started with an SDI-12 data recorder, my advice is to use the logic shown in the data recorder flow chart (appendix B-1). Likewise with the sensor flow chart (appendix B-2). Working together, both algorithms provide insurance for the proper communication between SDI-12 data recorders and sensors.

Mike Jablonski
NR Systems, Inc.
135 East Center
Logan, Utah 84321
435-752-4200
435-752-1691 (FAX)

TAX EXEMPT STATUS

The SDI-12 Support Group is a non-profit corporation, which is exempt from federal income taxes under section 501(a) on the Internal Revenue Code. The corporation is registered in the state of Utah.

ADDRESS CHANGE

Enviro-Systems, Div. of JGS Enterprises, Inc., reports that they have moved into a new and

larger facility in Camarillo, California. This move gives them expanded engineering offices and larger production areas for expansion of new product developments. Their new address is:

Enviro-Systems
Div of JGS Enterprises, Inc.
671 Via Alondra, #811A
Camarillo, Ca 93012
(818) 242-6096
(818) 242-2516 (FAX)

WEB PAGE ADDRESS

The SDI-12 Support Group's web page address is:

<http://www.sdi-12.org>

The web page has links to companies that are members of the SDI-12 Support Group. If you would like us to add a link to your web page, please send us your web page address. Your company must be a member of the SDI-12 Support Group to have a link from our web page.

The SDI-12 Specification can be downloaded from the web page, or you can also get a copy from NR Systems, (435) 752-4200/ (435) 752-1691 (FAX).

SDI-12 SUPPORT GROUP CORPORATE NEWS

SUMMER 1998

Terrell Fletcher
Design Analysis Associates, Inc.
75 West 100 South
Logan, UT 84321
435-753-2212/435-753-7669 (FAX)

Mike Jablonski
NR Systems, Inc.
135 East Center
Logan, UT 84321
435-752-4200/435-752-1691 (FAX)

Roy Johnson
U.S. Geological Survey
Building 2101
Stennis Space Center, MS 39529
601-688-1541/601-688-1577 (FAX)

Rick Lockyer
Handar, Inc.
1288 Reamwood Avenue
Sunnyvale, CA 94089
408-734-9640/408-734-0655 (FAX)

SDI-12 SUPPORT GROUP MEMBERS

AMASS DATA TECHNOLOGIES, INC.
AMJ EQUIPMENT CORPORATION
ATMOSPHERIC & ENVIRONMENTAL SERVICES
CAMPBELL SCIENTIFIC, INC.
CAMPBELL SCIENTIFIC (CANADA), CORPORATION
CLIMATRONICS CORPORATION
COASTAL ENVIRONMENTAL SYSTEMS
DESIGN ANALYSIS ASSOCIATE, INC.
DRUCK INCORPORATED
ENVIRO SYSTEMS
ENVIRONMENTAL SYSTEMS CORPORATION
ENVIRONMENT CANADA
FCI ENVIRONMENTAL, INC.
FOREST TECHNOLOGY SYSTEMS, INC.
GEOMATION, INC.
HANDAR, INC.
HYDROLAB CORPORATION
HYDROLOGIC H2I, INC.
IN-SITU, INC.
MET ONE NORTHWEST, INC.
MINDATA PTY, LTD
NR SYSTEMS, INC.

PAROSCIENTIFIC, INC.
RAINWISE, INC.
RITTMAYER, LTD.
SETRA SYSTEMS, INC.
SIGNAL ENGINEERING, INC.
SLOPE INDICATOR CO.
SOLOMAT
SOUTH FLORIDA WATER MANAGEMENT
STEVENS WATER MONITORING SYSTEMS
SUTRON CORPORATION
TAVIS CORPORATION
TROXLER ELECTRONIC LABORATORIES, INC.
U.S. GEOLOGICAL SURVEY
VITEL, INC.
YSI, Inc.

The SDI-12 Support Group is organized exclusively for educational and scientific purposes. The educational purpose is to inform all interested parties about the SDI-12 interface by providing all interested parties with copies of the SDI-12 Specification and providing other information, as appropriate, about the SDI-12 Specification. The scientific purpose is to publish the SDI-12 Specification and to upgrade the Specification when technical changes are necessary to facilitate the collection of environmental data using the SDI-12 Specification.

SDI-12 SUPPORT GROUP

SERIAL DATA INTERFACE AT 1200 BAUD

Membership Dues

Name: _____ Company: _____

Address: _____

City, State, Zip: _____

Phone: _____ Fax: _____ e-mail: _____

Dues are \$120.00 per year. *Membership dues are not deductible as charitable contributions for Federal Income Tax purposes.*
Make your check payable to the SDI-12 Support Group and return this page to:

SDI-12 Support Group
c/o NR Systems, Inc.
135 East Center
Logan, Utah 84321