

PROPOSED CHANGES TO SDI-12

SDI-12 is currently at Version 1.2, dated October 1996. Over the past two years, several proposed upgrades have been suggested to the SDI-12 Specification. The Technical Committee discussed these proposed upgrades at the 1998 annual meeting of the SDI-12 Support Group. That meeting was held last November, in Point Clear, Alabama, in conjunction with the annual American Water Resources Association's (AWRA) conference.

At the 1998 meeting of the Technical Committee the following changes were formally recommended by the Technical Committee:

- 1) Adding a Cyclic Redundancy Check (CRC) to data returned from SDI-12 Sensors;
- 2) Changing the Data Line "OFF" impedance to be less restrictive;
- 3) Rewording the section in the specification about inductive loading;
- 4) Clarifying the definition of low-power standby mode.

Pursuant to the bylaws of the SDI-12 Support Group, it takes a two-thirds majority, of those who return ballots, to make a change to the SDI-12 Specification. Please take the time to review the description of each proposed change and submit your ballot. The Technical Committee has formally recommended that these changes be adopted. Upon approval of at least one of the proposed changes, the Version of SDI-12 will be changed from version 1.2 to version 1.3 and a revised copy of the Specification will be mailed to each member of the SDI-12 Support Group.

Ballots are due by June 15, 1999.

INCREASING THE SIZE OF THE TECHNICAL COMMITTEE

By ballot on the summer 1997 newsletter, the maximum size of the Technical Committee was

increased from nine to ten members. The intention in 1997, however, was to increase the size of the technical committee to 12 members. By mistake the number 10 (not 12) appeared on the actual ballot that went out to the membership in 1997. Therefore, we are redoing this vote. Please vote, yes or no, on increasing the size of the technical committee from 10 to 12 members.

CRC-16

To enhance the error detection capability in SDI-12 data collection systems, a request was made to the technical committee to add CRC-16 error checking capability to the specification. To ensure maximum compatibility with existing systems, the technical committee proposes that new commands be added that request the data with a CRC-16 appended. To help eliminate conflicts with any existing sensors, the new measurement commands with CRC-16 requested will use the existing command letters with a C appended. Namely: aMC!, aMC1! ... aMC9!, aCC!, aCC1! ... aCC9!, and aRC0! ... aRC9!

CRC-16 COMPUTATION

Computation is performed on data response string BEFORE parity is added. All operations are assumed to be on 16 bit unsigned integers. The least significant bit is on the right. Numbers preceded by 0x are assumed to be hexadecimal.

Initialize CRC to zero. For each character beginning with the address up to but not including the carriage return

```
{
    Set the CRC equal to the exclusive OR of the character and itself
    For count = 1 to 8
    {
        If the least significant bit of the CRC is one
        {
            Right shift the CRC one bit
            Set CRC equal to the exclusive OR of 0xA001 and itself.
        }
        else
        {
            Right shift the CRC one bit
        }
    }
}
```

CRC-16 TRANSMISSION

The 16 bit CRC is encoded to three ASCII characters using the following algorithm:

1st character = 0x40 OR (CRC shifted right 12 bits)

2nd character = 0x40 OR (CRC shifted right 6 bits) and then AND 0x3f)

3rd character = 0x40 OR (CRC AND 0x3f)

(Continued on pg. 2)

(Cont....)

The three characters are placed after the data and before the <CR><LF>. Parity is applied to all three characters when they are transmitted, just like the rest of the transmitted data.

Examples of the CRC-16 Start Measurement Command (aMC!) and the Send Data Command (aD0!)

a. One measurement is immediately available after the MC command:

```
0MC!00001<CR><LF>
0D0!0+3.140qZ<CR><LF>
```

b. Three measurements will be ready 5 seconds after the MC command, and the sensor issues a service request. All 3 measurements are returned in response to the D0 command:

```
0MC!00053<CR><LF>
0<CR><LF>
0D0!0+3.14+2.718+1.414Ipz<CR><LF>
```

c. Nine measurements will be ready 35 seconds after the MC command, and the sensor issues a service request. Because the number of characters (excluding the CRC-16 characters) in all 9 measurements is greater than 38, a D1 command must be issued to get the second group of measurements:

```
0MC!00359<CR><LF>
0<CR><LF>
0D0!0+1.11+2.22+3.33+4.44+5.55+6.66Ijq<CR><LF>
0D1!0+7.77+8.88+9.99IvW<CR><LF>
```

d. Two measurements will be available in 1 second, and the sensor does not issue a service request. After 1 second, the data recorder sends a break to wake the sensor and issues the D0 command:

```
0MC!00012<CR><LF>
0D0!0+3.14+2.718IWO<CR><LF>
```

e. Three measurements will be ready 5 seconds after the MC command, and the sensor issues a service request. Upon receipt of the service request, the data recorder issues D0 to get the data. However, only 1 measurement is returned. The data recorder then issues the D1 command to get the next group of data. In response, the second measurement is returned. Then the recorder issues D2 to get the next, and last, group of data. In the example, each group contains only one measurement.

```
0MC!00053<CR><LF>
0<CR><LF>
0D0!0+3.140qZ<CR><LF>
0D1!0+2.718Gbc<CR><LF>
0D2!0+1.414GtW<CR><LF>
```

Note: This is in compliance with the standard. As many measurements as possible, however, should be returned in response to each D command.

f. Two sensors, one returning 12 readings after 45 seconds and the other returning 4 readings after 15 seconds. The measurements are taken concurrently. Fifteen seconds after requesting data from sensor 1, the data recorder issues a break followed by the D0 command to sensor address 1. Forty-five seconds (or longer) after requesting data from the sensor at address 0, the data recorder sends a break and a D0 command to sensor 0. Note that since a concurrent measurement was requested of sensor 0, it is allowed to return up to 78 characters (excluding the CRC-16 characters) in its response.

```
0CC!004512<CR><LF>
1CC!101504<CR><LF>
1D0!1+1.23+2.34+345+4.4678KoO<CR><LF>
0D0!0+1.234-4.56+12354-0.00045+2.223+145.5+7.7003+4328.8+9+10+11.433+12Ba]<CR><LF>
```

DATA LINE "OFF" IMPEDANCE

The data line off impedance in version 1.2 is specified as 200K \pm 10% by virtue of not having an explicit tolerance or range of values called out. It was decided that this was unnecessarily restrictive and that the specification should be changed to an explicit range of values. It was decided to submit a proposal to change the off impedance from the 200K with the implied \pm 10% tolerance to an explicit range of 160K to 360K ohms.

LOWPOWER STANDBY MODE

Due to confusion by some manufacturers, it was decided that a clarification should be added to Section 5 of the SDI-12 Specification. The clarification would be the following note.

Note: The lowpower standby mode, in addition to being a power consumption state, is a protocol state and a break is required to leave that state.

INDUCTIVE LOADING AND RECOMMENDED CONNECTION TO 12V

It was decided that the 1st sentence of the 2nd paragraph of section 3.3, of the SDI-12 Specification should be changed to:

For sensors connected to the 12volt line that exhibit an inductive load, a series diode is recommended. The diagram in appendix A of the SDI-12 Specification will be updated to show a series diode in the 12volt line connection. Figure 1 shows this circuit with the diode.

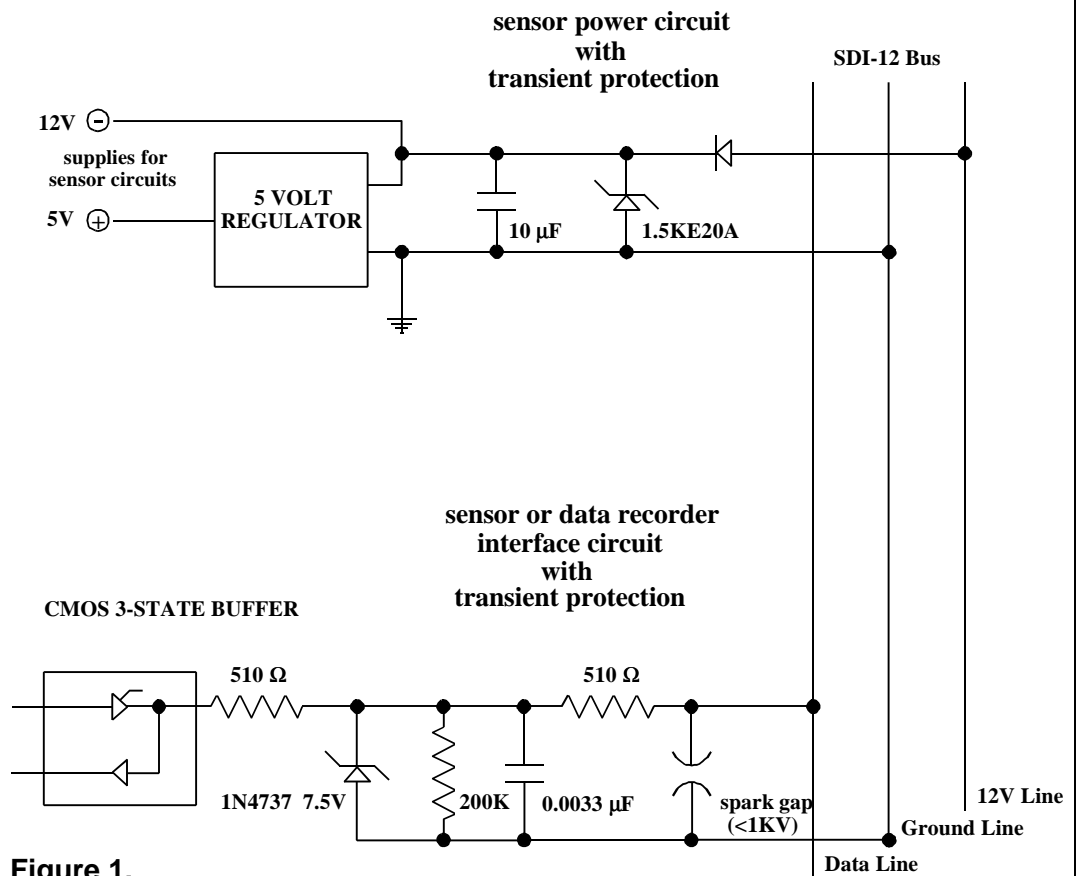

Figure 1.

DIFFERENTIAL SDI-12

The question of possible support for differential SDI-12 to support longer data lines was reviewed by the Technical Committee. The question was whether differential support could be added in a manner that also supported conventional single ended SDI-12 in the same unit and would allow intermixing the two types in the same system. The following circuit was suggested as a solution. This circuit will be evaluated before being proposed as a specification amendment to the SDI-12 Specification.

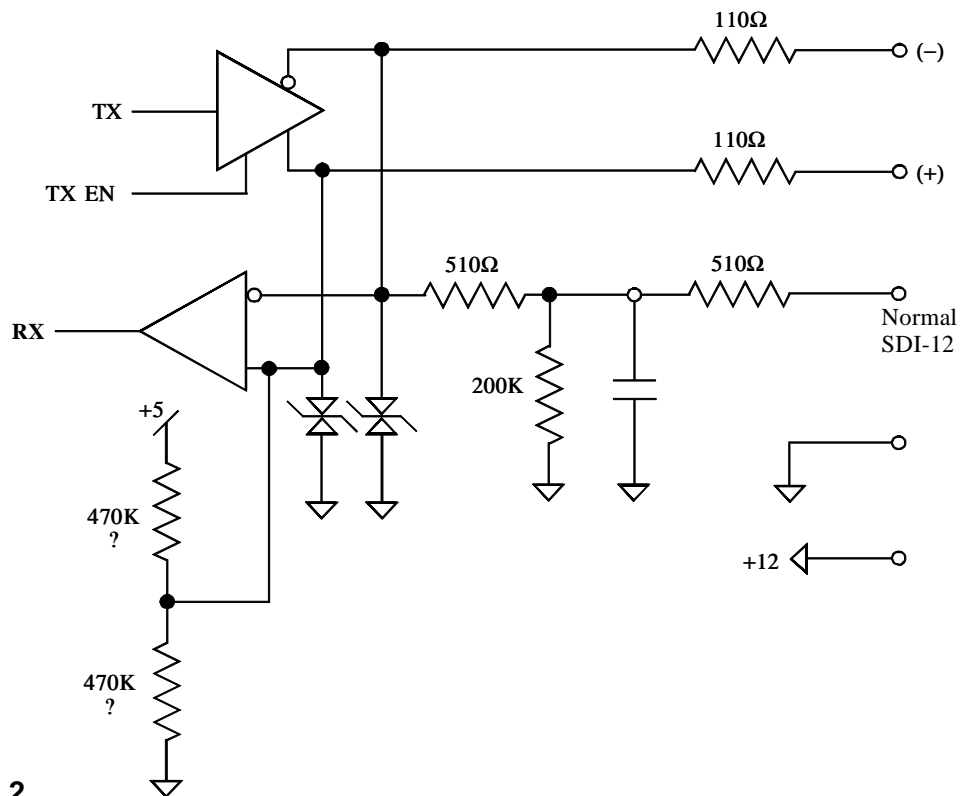

Figure 2.

SDI-12 Support Group Corporate News

Spring 1999

BOARD OF DIRECTORS

MICHAEL JABLONSKI, CHAIRMAN
GERALD CALHOUN, BOARD MEMBER
WILLIAM P. THOMAS, SECRETARY

SDI-12 SUPPORT GROUP MEMBERS

ADCON TELEMETRY
AMASS DATA TECHNOLOGIES, INC.
AMJ EQUIPMENT CORPORATION
CAMPBELL SCIENTIFIC, INC.
CAMPBELL SCIENTIFIC (CANADA), CORPORATION
CLIMATRONICS CORPORATION
COASTAL ENVIRONMENTAL SYSTEMS DESIGN ANALYSIS ASSOCIATE, INC.
DRUCK INCORPORATED
ENVIRO SYSTEMS
ENVIRONMENTAL SYSTEMS CORPORATION
ENVIRONMENT CANADA
FCI ENVIRONMENTAL, INC.
FOREST TECHNOLOGY SYSTEMS, INC.
GEOMATION, INC.
HANDAR, INC.
HYDROLAB CORPORATION
HYDROLOGIC H2I, INC.
MINDATA PTY, LTD
NR SYSTEMS, INC.
OTT HYDROMETRY
PAROSCIENTIFIC, INC.
RITTMAYER, LTD.
SIGNAL ENGINEERING, INC.
SOUTH FLORIDA WATER MANAGEMENT
STEVENS WATER MONITORING SYSTEMS
SUTRON CORPORATION
TAVIS CORPORATION
U.S. GEOLOGICAL SURVEY
VITEL, INC.
YSI, INC.

TECHNICAL COMMITTEE

Albrecht Dorr
OTT MESSTECHNIK GMBH & Co. KG
Postfach 2140
87411 Kempten Germany
++49-(0)831-5617-0/(Fax)++49-(0)831-5617-209
info@ott-hydrometry.de

Jan Matthews
Druck Inc.
4 Dunham Dr.
New Fairfield, CT 06812
203-746-0400/(Fax)203-746-2494
mattroch@ix.netcom.com

Jerry Calhoun, Chairman
Sutron Corporation
21300 Ridgetop Cir.
Sterling, VA 20166
703-406-2800/(Fax)703-406-2801
jcalhoun@sutron.com

Jim Betzhold
South Florida Water Management District
Building A-100
7257 West Port Place
West Palm Beach, FL 33413
561-682-6972/(Fax)561-697-7291
jbetzho@sfwmd.gov

Joe Thurston
Campbell Scientific, Inc.
815 West 1800 North
Logan, UT 84321
435-750-2342/(Fax)435-750-9540
joe@campbellsci.com

Mike Jablonski
NR Systems, Inc.
135 East Center
Logan, Utah 84321
435-752-4200/(Fax)435-752-1691
nrsys@sisna.com

Paul-Emile Bergeron
Environment Canada
131 Greber Blvd
Gatineau, Quebec
Canada J8T 3R1
819-997-1398/(Fax)
paul-emile.bergeron@ec.gc.ca

Rick Lockyer
Handar, Inc
1288 Reamwood Avenue
Sunnyvale, CA 94089
408-734-9640/(Fax)408-734-0655
rlockyer@handar.com

Roy Johnson
U.S. Geological Survey
Building 2101
Stennis Space Center, MS 39529
601-688-1541/(Fax)601-688-1577
rajohn@usgs.gov

Terry Dickey
Hydrolab Corporation
12921 Burnet Rd.
Austin, TX 78763
512-255-8841/(Fax)512-255-3106
engineer@hydrolab.com

TAX EXEMPT STATUS

The SDI-12 Support Group is a non-profit corporation, which is exempt from federal income taxes under section 501(a) on the Internal Revenue Code. The corporation is registered in the state of Utah.

WEB PAGE ADDRESS

SDI-12 Support Group's web page address is:

<http://www.sdi-12.org>

The web page has links to companies that are members of the SDI-12 Support Group. If you would like us to add a link to your web page, please send us your web page address. Your company must be a member of the SDI-12 Support Group to have a link from our web page.

1999 MEMBERSHIP DUES

The yearly membership dues of \$120 are now due. Membership dues are used to maintain the website, for production of the newsletter, postage expenses, printing costs, and all other expenses of the SDI-12 Support Group. New members are welcome. Please join us.

The SDI-12 Support Group is organized exclusively for educational and scientific purposes. The educational purpose is to inform all interested parties about the SDI-12 interface by providing all interested parties with copies of the SDI-12 Specification and providing other information, as appropriate, about the SDI-12 Specification. The scientific purpose is to publish the SDI-12 Specification and to upgrade the Specification when technical changes are necessary to facilitate the collection of environmental data using the SDI-12 Specification.

BALLOT

1) Do you agree to add the new commands that will support a 16 bit Cyclic Redundancy Check (CRC)? The CRC value will be encoded as three ASCII characters and appended to the data values that are returned via the standard D (get data) commands. The new commands will be:

Yes_____ No_____

aMC!, aMC1! . . . aMC9!
aCC!, aCC1! . . . aCC9!
aRC0!, aRC1! . . . aRC9!

2) Do you agree to change the SDI-12 Specification to change the data line off impedance from 200K with an implied $\pm 10\%$ tolerance to an explicit range of 160K to 360K Ohms?

Yes_____ No_____

3) Do you agree to clarify the definition of low power standby mode by adding the following statement to the SDI-12 Specification:

Yes_____ No_____

“The low power standby mode, in addition to being a power consumption state, is a protocol state and a break is required to leave that state.”

4) Do you agree to clarify the statement about inductive loads on the 12V line, by recommending the use of a series diode on the 12V line? (See Figure 1.)

Yes_____ No_____

5) Do you agree to increase the size of the Technical Committee from 10 to 12 members?

Yes_____ No_____

SDI-12 SUPPORT GROUP

SERIAL DATA INTERFACE AT 1200 BAUD

1999 Membership Dues

Name: _____ Company: _____

Address: _____

City, State, Zip: _____

Phone: _____ Fax: _____ e-mail: _____

Can we add a link to your webpage from the SDI-12 Support Group's webpage? Yes _____ No _____

If yes, what is your webpage address: _____

Dues are \$120.00 per year. Membership dues are not deductible as charitable contributions for Federal Income Tax purposes. Make your check payable to the SDI-12 Support Group and return this page to:

SDI-12 Support Group
c/o NR Systems, Inc.
135 East Center
Logan, Utah 84321